

Visual Cooking 8

Bake-off ovens model B / BPE
 Capacity: 8 x 400x600 mm trays



General features

- Steam technology: injection steam
- Reversible fan ensures perfect roasting and baking
- Adjustable fan speed with 9 steps
- Optional door hinging, left (standard) or right
- Optional distance between runners, 85 mm or 65 mm
- Optional tray size, 400x600 mm (standard) or 1/1 GN
- 2-piece rack, lengthwise insertion
- Easy-to-clean design
- IP X5 protection
- Cabinet and oven chamber in BS 304 S 31 stainless steel
- Rounded corners in oven chamber
- Easily detachable door seal
- Halogen light in oven chamber
- Table model prepared for stand
- Timer function with current time, date and timer
- Manual humidity pulsing
- Preheating up to 300°C

General operating modes

- Hot air: 30-250°C
- Proving: 30-40°C

Scandinavian safety concept

- Oven door with ventilated heat-reflecting glass
- CTD Cool Touch Door (max. outside temperature of 65°C)
- 2-step door handle in stainless steel for optimum safety
- Integrated drip tray in stainless steel, self-emptying
- Automatic door stop at 110° and 180°
- Runners with stop
- Max. working height of 135 cm incl. stand

B ovens standard features

Panel with turn switch and digital display
 Memory of 10 programmes - each with up to 3 steps
 Cook book with 5 preset programmes
 Combi 1 and Combi 2: 30-250°C
 Semi-automatic cleaning system
 Automatic cooling
 Error registration system



BPE ovens standard features

Panel with soft keys and TFT display
 Memory of 200 programmes - each with up to 10 steps
 Cook book with 65 preset programmes
 KlimaOptima® automatic humidity control: 70-250°C
 CombiWash® fully automatic cleaning system
 Integrated hand shower
 Cook & Regen: 30-180°C
 Manual or automatic cooling
 Automatic service diagnosis system
 HACCP quality control
 USB connection



Optional features (visit www.houno.com)

CombiWash® fully automatic cleaning system (B)
 Integrated hand shower (B)
 Remote control and online access with CombiNet® (BPE)
 Extraction hood with or without steam condensator
 Removable cassette rack
 Trolley for rack
 Storage trolley
 Cover for storage trolley
 Stacking kit for CombiPlus (5)
 Extra door, PassThrough version
 Stands e.g. with runners or shelf
 Various voltages

Visual Cooking 8

Bake-off ovens model B / BPE
Capacity: 8 stk. 400x600 mm plader

Visual Cooking

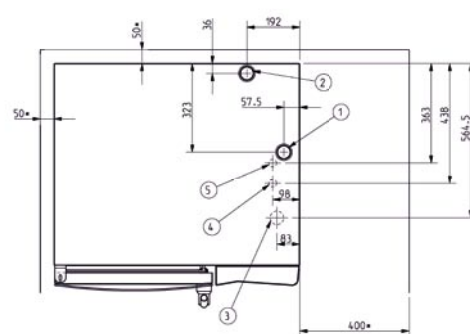
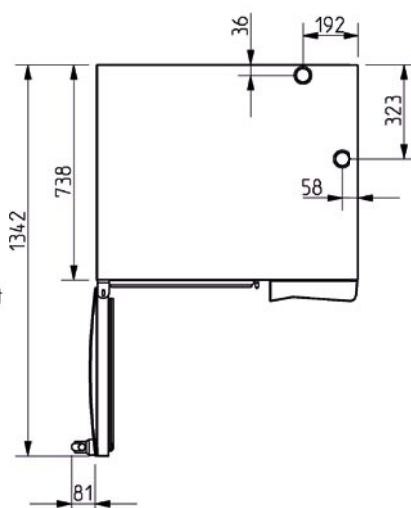
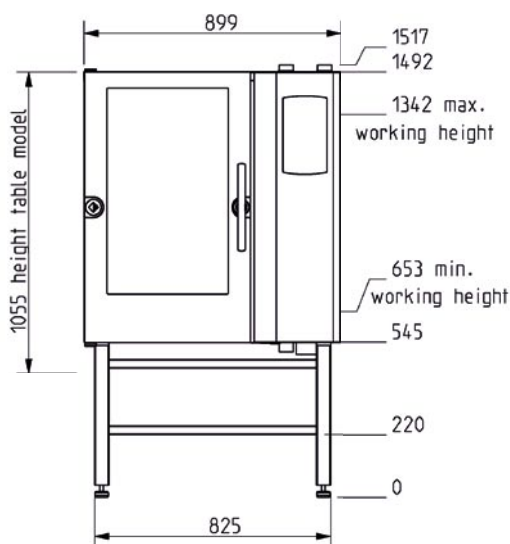

Installation 1/1 GN

- ① Ø 50 mm exhaust tube
- ② Ø 50 mm tube for drain connection
- ③ Lead-in for supply line
- ④ 3/4" water connection for soft water
- ⑤ Option together with ④
3/4" water connection for raw water

Consult HOUNÖ's Service & Installation manual for further information.

CAPACITY	
Tray size	400 x 600 eller 1/1 GN
Number of runners, 85 mm	8
Rolls	160
Loaves, 600 g	32
Baguettes, 56 cm	32
Danish pastry	92
SPECIFICATIONS	
Voltage	400V AC 3N + E 50/60 Hz
Wattage	18 kW
Current	26 A
Water connection	3/4" outside
Drain	Ø 50 mm outside

DIMENSIONS	OVEN
Width	900 mm
Height - table model	1055 mm
Height with stand	1495 mm
Depth (excl. handle)	831 mm
Weight	175 kg
DIMENSIONS	OVEN PACKED
Width	1200 mm
Height - table model	1255 mm
Height with stand	1700 mm
Depth (excl. handle)	1000 mm
Weight	190 kg