

Visual Cooking 2.14

Combi ovens model K / KPE
 Capacity: 14 x 2/1 GN trays or
 28 x 1/1 GN trays



General features

- Steam technology: steam generator
- Reversible fan ensures perfect roasting and baking
- Adjustable fan speed with 9 steps
- Optional door hinging, left (standard) or right
- Optional distance between runners, 65 mm or 85 mm
- Optional tray size, 2/1 GN (standard) or 1/1 GN
- Cassette rack
- Easy-to-clean design
- IP X5 protection
- Cabinet and oven chamber in BS 304 S 31 stainless steel
- Rounded corners in oven chamber
- Easily detachable door seal
- Indicator of water shortage in steam generator
- AFS Auto Flush System in steam generator
- Halogen light in oven chamber
- Table model prepared for stand
- Timer function with current time, date and timer
- Manual humidity pulsing
- Preheating up to 300°C

General operating modes

- Hot air: 30-250°C
- Low-temperature steaming: 30-99°C
- Steaming: 100°C
- Forced steaming: 120°C
- Cook & Regen: 30-180°C

Scandinavian safety concept

- Oven door with ventilated heat-reflecting glass
- CTD Cool Touch Door (max. outside temperature of 65°C)
- 2-step door handle in stainless steel for optimum safety
- Integrated drip tray in stainless steel, self-emptying
- Automatic door stop at 110° and 180°
- Runners with stop
- Max. working height of 135 cm incl. stand

K ovens standard features

Panel with turn switch and digital display
 Memory of 10 programmes - each with up to 3 steps
 Cook book with 5 preset programmes
 Combi 1 and Combi 2: 30-250°C
 Semi-automatic cleaning system
 Automatic cooling
 Error registration system



KPE ovens standard features

Panel with soft keys and TFT display
 Memory of 200 programmes - each with up to 10 steps
 Cook book with 65 preset programmes
 ClimaOptima® automatic humidity control: 70-250°C
 Proving: 30-40°C
 CombiWash® fully automatic cleaning system
 Integrated hand shower
 Manual or automatic cooling
 Automatic service diagnosis system
 Multi-point probe, external location
 Delta-T and Cook & Hold
 HACCP quality control
 USB connection



Optional features (visit www.houno.com)

CombiWash® fully automatic cleaning system (K)
 Integrated hand shower (K)
 Multi-point probe, external location (K)
 Extra multi-point probe, external location (KPE)
 Remote control with CombiNet® (KPE)
 Rack for plates, 72 or 85 plates
 Trolley for rack
 Insulating thermal blanket
 Marine version
 Stands e.g. with runners or shelf
 Various voltages
 Extraction hood with or without steam condenser

Visual Cooking 2.14

Combi ovens model K / KPE
Capacity: 14 x 2/1 GN trays
28 x 1/1 Gn trays

Visual Cooking

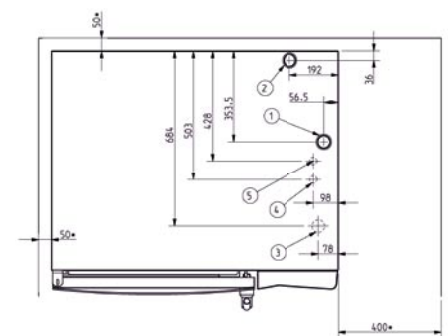
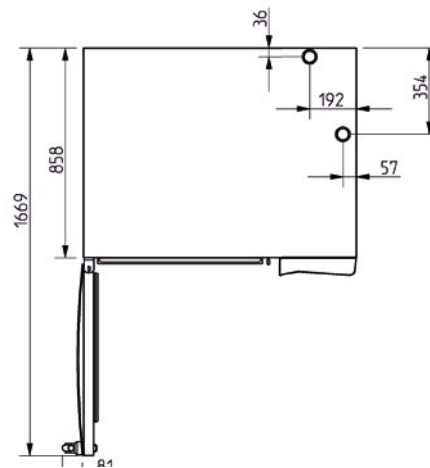
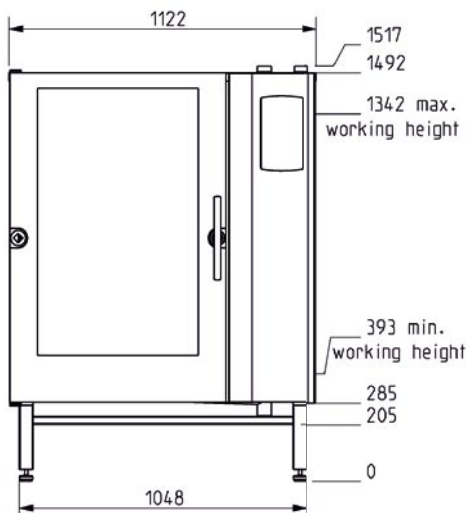

Installation 2/1 GN

- ① Ø 50 mm exhaust tube
- ② Ø 50 mm tube for drain connection
- ③ Lead-in for supply line
- ④ 3/4" water connection for soft water
- ⑤ Option together with ④
3/4" water connection for raw water

Consult HOUNÖ's Service & Installation manual for further information.

CAPACITY	
Tray size	2/1 GN eller 1/1 GN
Number of runners, 65 mm	14 (28)
Number of runners, 85 mm	11 (22)
Portions	420
Potatoes	112/89 kg
Rice	28 kg
Vegetables	70 kg
Roasts	84-96 kg
Chickens, 900 g	64 stk.
Rolls	420 stk.
SPECIFICATIONS	
Voltage	400V AC 3N + E 50/60 Hz
Wattage	27 kW
Current	39 A
Water connection	3/4" outside
Drain	Ø 50 mm outside

DIMENSIONS	OVEN
Width	1125 mm
Height - table model	1081 mm
Height with stand	1495 mm
Depth (excl. handle)	951 mm
Weight	235 kg
DIMENSIONS	OVEN PACKED
Width	1200 mm
Height - table model	1281 mm
Height with stand	1695 mm
Depth (excl. handle)	1000 mm
Weight	250 kg