

Visual Cooking 2.10

Combi ovens model C / CPE
 Capacity: 10 x 2/1 GN trays or
 20 x 1/1 GN trays



General features

- Steam technology: injection steam
- Reversible fan ensures perfect roasting and baking
- Adjustable fan speed with 9 steps
- Optional door hinging, left (standard) or right
- Optional distance between runners, 65 mm or 85 mm
- Optional tray size, 2/1 GN (standard) or 1/1 GN
- Cassette rack
- Easy-to-clean design
- IP X5 protection
- Cabinet and oven chamber in BS 304 S 31 stainless steel
- Rounded corners in oven chamber
- Easily detachable door seal
- Halogen light in oven chamber
- Table model prepared for stand
- Timer function with current time, date and timer
- Manual humidity pulsing
- Preheating up to 300°C

General operating modes

- Hot air: 30-250°C
- Steaming with injection steam: 30-120°C
- Cook & Regen: 30-180°C

Scandinavian safety concept

- Oven door with ventilated heat-reflecting glass
- CTD Cool Touch Door (max. outside temperature of 65°C)
- 2-step door handle in stainless steel for optimum safety
- Integrated drip tray in stainless steel, self-emptying
- Automatic door stop at 110° and 180°
- Runners with stop
- Max. working height of 135 cm incl. stand

C ovens standard features

Panel with turn switch and digital display
 Memory of 10 programmes - each with up to 3 steps
 Cook book with 5 preset programmes
 Combi 1 and Combi 2: 30-250°C
 Semi-automatic cleaning system
 Automatic cooling
 Error registration system



CPE ovens standard features

Panel with soft keys and TFT display
 Memory of 200 programmes - each with up to 10 steps
 Cook book with 65 preset programmes
 ClimaOptima® automatic humidity control: 70-250°C
 Proving: 30-40°C
 CombiWash® fully automatic cleaning system
 Integrated hand shower
 Manual or automatic cooling
 Automatic service diagnosis system
 HACCP quality control
 USB connection



Optional features (visit www.houno.com)

CombiWash® fully automatic cleaning system (C)
 Integrated hand shower (C)
 Multi-point probe, external location
 Extra multi-point probe, external location (CPE)
 Remote control and online access with CombiNet® (CPE)
 Removable cassette rack
 Rack for plates, 51 or 63 plates
 Trolley for rack
 Insulating thermal blanket
 Marine version
 Stands e.g. with runners or shelf
 Various voltages
 Extraction hood with or without steam condenser

Visual Cooking 2.10

Combi ovens model C / CPE
Capacity: 10 x 2/1 GN trays
20 x 1/1 GN trays

Visual Cooking

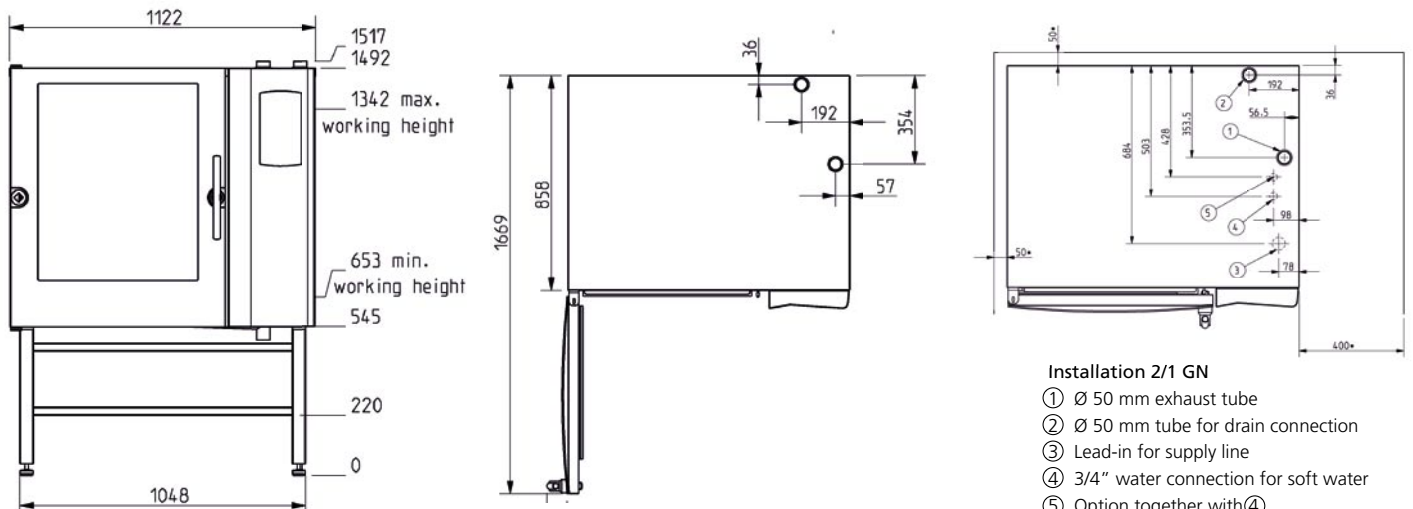

Installation 2/1 GN

- ① Ø 50 mm exhaust tube
- ② Ø 50 mm tube for drain connection
- ③ Lead-in for supply line
- ④ 3/4" water connection for soft water
- ⑤ Option together with ④
3/4" water connection for raw water

Consult HOUNÖ's Service & Installation manual for further information.

CAPACITY	
Tray size	2/1 GN eller 2/1 GN
Number of runners, 65 mm	10 (20)
Number of runners, 85 mm	8 (16)
Portions	300
Potatoes	80/64 kg
Rice	20 kg
Vegetables	50 kg
Roasts	60-70 kg
Chickens, 900 g	48 stk.
Rolls	300 stk.
SPECIFICATIONS	
Voltage	400V AC 3N + E 50/60 Hz
Wattage	27 kW
Current	39 A
Water connection	3/4" outside
Drain	Ø 50 mm outside

DIMENSIONS	OVEN
Width	1125 mm
Height - table model	1055 mm
Height with stand	1495 mm
Depth (excl. handle)	951 mm
Weight	215 kg
DIMENSIONS	OVEN PACKED
Width	1200 mm
Height - table model	1255 mm
Height with stand	1695 mm
Depth (excl. handle)	1000 mm
Weight	230 kg