

Visual Cooking 15 & 15 roll-in

Bake-off ovens model B / BPE

Capacity: 15 x 400x600 mm trays



General features

- Steam technology: injection steam
- Reversible fan ensures perfect roasting and baking
- Adjustable fan speed with 9 steps
- Optional door hinging, left (standard) or right (15)
- Left-hinged door (15 roll-in)
- Optional distance between runners, 85 mm or 65 mm
- Optional tray size, 400x600 mm (standard) or 1/1 GN
- Cassette rack, lengthwise insertion (15)
- Roll-in trolley with cassette rack (15 roll-in)
- Easy-to-clean design
- IP X5 protection
- Cabinet and oven chamber in BS 304 S 31 stainless steel
- Rounded corners in oven chamber
- Easily detachable door seal
- Halogen light in oven chamber
- Standard stand
- Timer function with current time, date and timer
- Manual humidity pulsing
- Preheating up to 300°C

General operating modes

- Hot air: 30-250°C
- Proving: 30-40°C

Scandinavian safety concept

- Oven door with ventilated heat-reflecting glass
- CTD Cool Touch Door (max. outside temperature of 65°C)
- 2-step door handle in stainless steel for optimum safety
- Integrated drip tray in stainless steel, self-emptying
- Automatic door stop at 110° and 180°
- Runners with stop

B ovens standard features

Panel with turn switch and digital display
 Memory of 10 programmes - each with up to 3 steps
 Cook book with 5 preset programmes
 Combi 1 and Combi 2: 30-250°C
 Semi-automatic cleaning system
 Automatic cooling
 Error registration system



BPE ovens standard features

Panel with soft keys and TFT display
 Memory of 200 programmes - each with up to 10 steps
 Cook book with 65 preset programmes
 ClimaOptima® automatic humidity control: 70-250°C
 CombiWash® fully automatic cleaning system
 Integrated hand shower
 Cook & Regen: 30-180°C
 Manual or automatic cooling
 Automatic service diagnosis system
 HACCP quality control
 USB connection



Optional features (visit www.houno.com)

CombiWash® fully automatic cleaning system (B)
 Integrated hand shower (B)
 Remote control and online access with CombiNet® (BPE)
 Extraction hood with or without steam condensator
 Trolley for rack (15)
 Extra roll-in trolley (15 roll-in)
 Storage trolley
 Cover for storage trolley
 Extra door, PassThrough version (15)
 Various voltages

Visual Cooking 15 & 15 roll-in

Bake-off ovens model B / BPE
Capacity: 15 stk. 400x600 mm trays

Visual Cooking

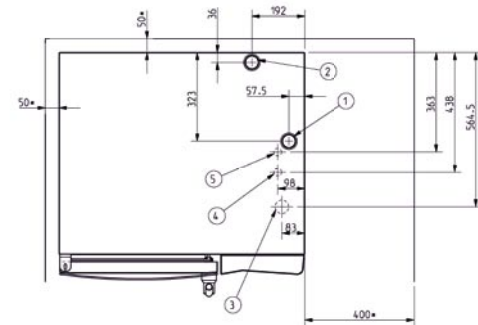
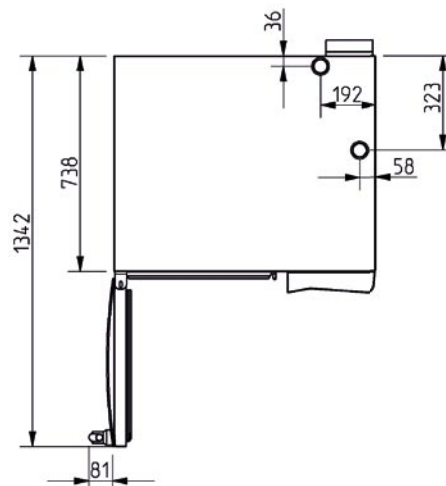
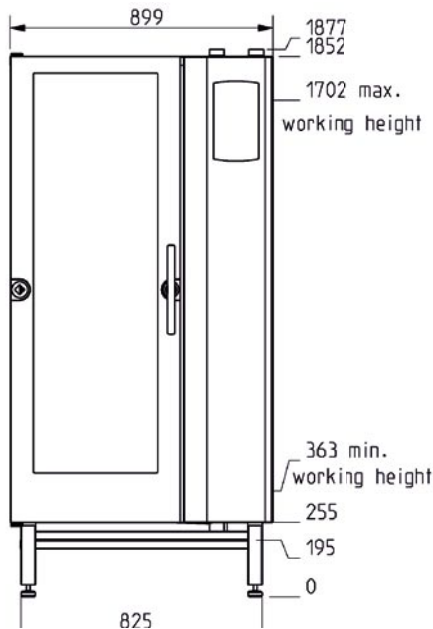

Installation 1/1 GN

- ① Ø 50 mm exhaust tube
- ② Ø 50 mm tube for drain connection
- ③ Lead-in for supply line
- ④ 3/4" water connection for soft water
- ⑤ Option together with ④
3/4" water connection for raw water

Consult HOUNÖ's Service & Installation manual for further information.

CAPACITY	
Tray size	400 x 600 eller 1/1 GN
Number of runners, 85 mm	15
Rolls	300
Loaves, 600 g	60
Baguettes, 56 cm	60
Danish pastry	180
SPECIFICATIONS	
Voltage	400V AC 3N + E 50/60 Hz
Wattage	36 kW
Current	52 A
Water connection	3/4" outside
Drain	Ø 50 mm outside

DIMENSIONS	OVEN
Width	900 mm
Height - table model	
Height with stand	1855 mm
Depth (excl. handle)	886 mm
Weight	255 kg
DIMENSIONS	OVEN PACKED
Width	1200 mm
Height - table model	
Height with stand	1700 mm
Depth (excl. handle)	1000 mm
Weight	270 kg