

Visual Cooking 1.20 & 1.20 roll-in

Combi ovens model C / CPE
 Capacity: 20 x 1/1 GN trays



General features

- Steam technology: injection steam
- Reversible fan ensures perfect roasting and baking
- Adjustable fan speed with 9 steps
- Optional door hinging, left (standard) or right (1.20)
- Left-hinged door (1.20 roll-in)
- Optional distance between runners, 65 mm or 85 mm
- Optional tray size, 1/1 GN (standard) or 400x600 mm
- Cassette rack, lengthwise insertion (1.20)
- Roll-in trolley with cassette rack (1.20 roll-in)
- Easy-to-clean design
- IP X5 protection
- Cabinet and oven chamber in BS 304 S 31 stainless steel
- Rounded corners in oven chamber
- Easily detachable door seal
- Halogen light in oven chamber
- Standard stand
- Timer function with current time, date and timer
- Manual humidity pulsing
- Preheating up to 300°C

General operating modes

- Hot air: 30-250°C
- Steaming with injection steam: 30-120°C
- Cook & Regen: 30-180°C

Scandinavian safety concept

- Oven door with ventilated heat-reflecting glass
- CTD Cool Touch Door (max. outside temperature of 65°C)
- 2-step door handle in stainless steel for optimum safety
- Integrated drip tray in stainless steel, self-emptying
- Automatic door stop at 110° and 180°
- Runners with stop

C ovens standard features

Panel with turn switch and digital display
 Memory of 10 programmes - each with up to 3 steps
 Cook book with 5 preset programmes
 Combi 1 and Combi 2: 30-250°C
 Semi-automatic cleaning system
 Automatic cooling
 Error registration system



CPE ovens standard features

Panel with soft keys and TFT display
 Memory of 200 programmes - each with up to 10 steps
 Cook book with 65 preset programmes
 KlimaOptima® automatic humidity control: 70-250°C
 Proving: 30-40°C
 CombiWash® fully automatic cleaning system
 Integrated hand shower
 Manual or automatic cooling
 Automatic service diagnosis system
 HACCP quality control
 USB connection



Optional features (visit www.houno.com)

CombiWash® fully automatic cleaning system (C)
 Integrated hand shower (C)
 Multi-point probe, external location
 Extra multi-point probe, external location (CPE)
 Remote control and online access with CombiNet® (CPE)
 Rack for plates, 48 or 57 plates
 Trolley for rack (1.20)
 Extra roll-in trolley (1.20 roll-in)
 Insulating thermal blanket
 Extra door, PassThrough version
 Marine version
 Various voltages
 Extraction hood with or without steam condenser

Visual Cooking 1.20 & 1.20 roll-in

Combi ovens model C / CPE
Capacity: 20 x 1/1 GN trays

Visual Cooking

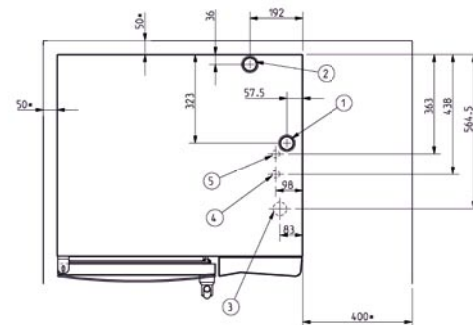
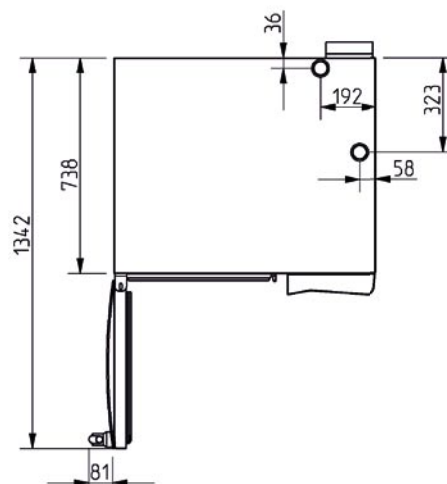
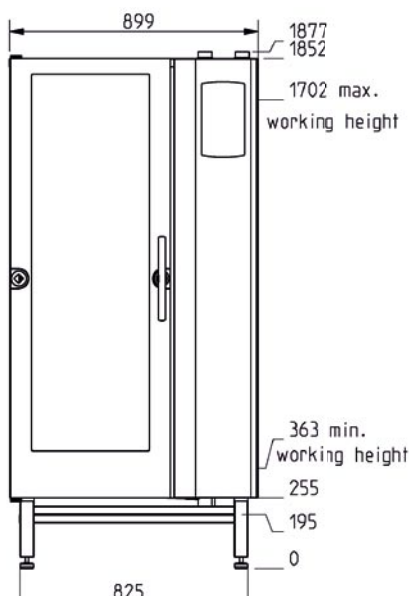

Installation 1/1 GN

- ① Ø 50 mm exhaust tube
- ② Ø 50 mm tube for drain connection
- ③ Lead-in for supply line
- ④ 3/4" water connection for soft water
- ⑤ Option together with ④
3/4" water connection for raw water

Consult HOUNÖ's Service & Installation manual for further information.

| CAPACITY | |
|--------------------------|-------------------------|
| Tray size | 1/1 GN eller 400 x 600 |
| Number of runners, 65 mm | 20 |
| Number of runners, 85 mm | 15 |
| Portions | 300 |
| Potatoes | 80/64 kg |
| Rice | 20 kg |
| Vegetables | 50 kg |
| Roasts | 60-70 kg |
| Chickens, 900 g | 48 stk. |
| Rolls | 300 stk. |
| SPECIFICATIONS | |
| Voltage | 400V AC 3N + E 50/60 Hz |
| Wattage | 36 kW |
| Current | 52 A |
| Water connection | 3/4" outside |
| Drain | Ø 50 mm outside |

| DIMENSIONS | OVEN |
|----------------------|-------------|
| Width | 900 mm |
| Height - table model | |
| Height with stand | 1855 mm |
| Depth (excl. handle) | 886 mm |
| Weight | 255 kg |
| DIMENSIONS | OVEN PACKED |
| Width | 1200 mm |
| Height - table model | |
| Height with stand | 2055 mm |
| Depth (excl. handle) | 1000 mm |
| Weight | 270 kg |