

## Visual Cooking 1.16

Combi ovens model K / KPE  
 Capacity: 16 x 1/1 GN trays



### General features

- Steam technology: steam generator
- Reversible fan ensures perfect roasting and baking
- Adjustable fan speed with 9 steps
- Optional door hinging, left (standard) or right
- Optional distance between runners, 65 mm or 85 mm
- Optional trays size, 1/1 GN (standard) or 400x600 mm
- Cassette rack, lengthwise insertion
- Easy-to-clean design
- IP X5 protection
- Cabinet and oven chamber in BS 304 S 31 stainless steel
- Rounded corners in oven chamber
- Easily detachable door seal
- Indicator of water shortage in steam generator
- AFS Auto Flush System in steam generator
- Halogen light in oven chamber
- Standard stand
- Timer function with current time, date and timer
- Manual humidity pulsing
- Preheating up to 300°C

### General operating modes

- Hot air: 30-250°C
- Low-temperature steaming: 30-99°C
- Steaming: 100°C
- Forced steaming: 120°C
- Cook & Regen: 30-180°C

### Scandinavian safety concept

- Oven door with ventilated heat-reflecting glass
- CTD Cool Touch Door (max. outside temperature of 65°C)
- 2-step door handle in stainless steel for optimum safety
- Integrated drip tray in stainless steel, self-emptying
- Automatic door stop at 110° and 180°
- Runners with stop

### K ovens standard features

Panel with turn switch and digital display  
 Memory of 10 programmes - each with up to 3 steps  
 Cook book with 5 preset programmes  
 Combi 1 and Combi 2: 30-250°C  
 Semi-automatic cleaning system  
 Automatic cooling  
 Error registration system



### KPE ovens standard features

Panel with soft keys and TFT display  
 Memory of 200 programmes - each with up to 10 steps  
 Cook book with 65 preset programmes  
 ClimaOptima® automatic humidity control: 70-250°C  
 Proving: 30-40°C  
 CombiWash® fully automatic cleaning system  
 Integrated hand shower  
 Manual or automatic cooling  
 Automatic service diagnosis system  
 Multi-point probe, external location  
 Delta-T and Cook & Hold  
 HACCP quality control  
 USB connection



### Optional features (visit [www.houno.com](http://www.houno.com))

CombiWash® fully automatic cleaning system (K)  
 Integrated hand shower (K)  
 Multi-point probe, external location (K)  
 Extra multi-point probe, external location (KPE)  
 Removable cassette rack  
 Rack for plates, 42 or 50 plates  
 Trolley for rack  
 Insulating thermal blanket  
 Extra door, PassThrough version  
 Marine version  
 Various voltages  
 Extraction hood with or without steam condenser

# Visual Cooking 1.16

Combi ovens model K / KPE  
Capacity: 16 x 1/1 GN trays

*Visual Cooking*

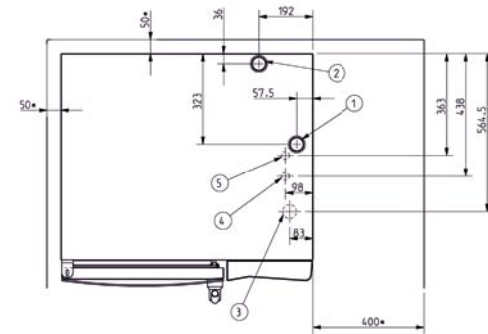
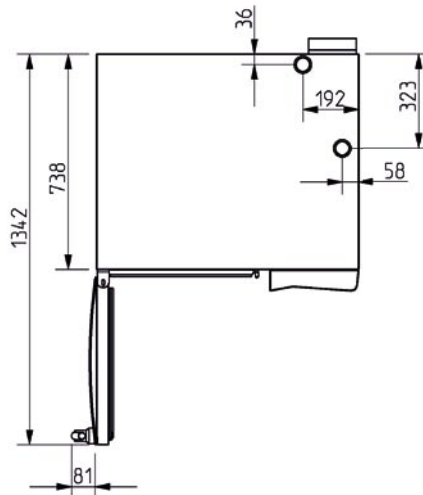
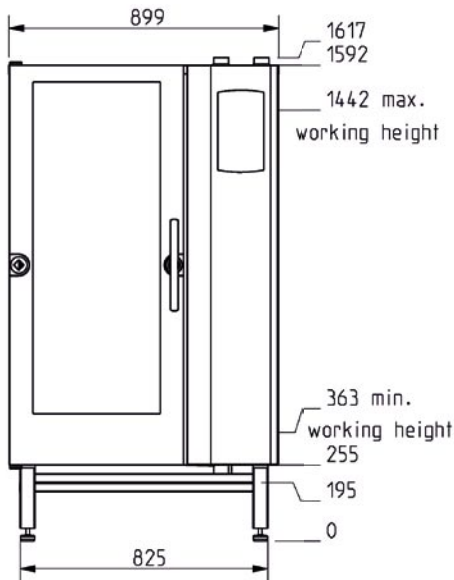

**Installation 1/1 GN**

- ① Ø 50 mm exhaust tube
- ② Ø 50 mm tube for drain connection
- ③ Lead-in for supply line
- ④ 3/4" water connection for soft water
- ⑤ Option together with ④  
3/4" water connection for raw water

Consult HOUNÖ's Service & Installation manual for further information.

CAPACITY	
Tray size	1/1 GN eller 400 x 600
Number of runners, 65 mm	16
Number of runners, 85 mm	12
Portions	240
Potatoes	64/51 kg
Rice	16 kg
Vegetables	40 kg
Roasts	48-56 kg
Chickens, 900 g	40 stk.
Rolls	240 stk.
SPECIFICATIONS	
Voltage	400V AC 3N + E 50/60 Hz
Wattage	24 kW
Current	35 A
Water connection	3/4" outside
Drain	Ø 50 mm outside

DIMENSIONS	OVEN
Width	900 mm
Height - table model	
Height with stand	1595 mm
Depth (excl. handle)	886 mm
Weight	225 kg
DIMENSIONS	OVEN PACKED
Width	1200 mm
Height - table model	
Height with stand	1800 mm
Depth (excl. handle)	1000 mm
Weight	240 kg