

Visual Cooking 1.10

Combi ovens model K / KPE
 Capacity: 10 x 1/1 GN trays



General features

- Steam technology: steam generator
- Reversible fan ensures perfect roasting and baking
- Adjustable fan speed with 9 steps
- Optional door hinging, left (standard) or right
- Optional distance between runners, 65 mm or 85 mm
- Optional trays size, 1/1 GN (standard) or 400x600 mm
- 2-piece rack, lengthwise insertion
- Easy-to-clean design
- IP X5 protection
- Cabinet and oven chamber in BS 304 S 31 stainless steel
- Rounded corners in oven chamber
- Easily detachable door seal
- Indicator of water shortage in steam generator
- AFS Auto Flush System in steam generator
- Halogen light in oven chamber
- Table model prepared for stand
- Timer function with current time, date and timer
- Manual humidity pulsing
- Preheating up to 300°C

General operating modes

- Hot air: 30-250°C
- Low-temperature steaming: 30-99°C
- Steaming: 100°C
- Forced steaming: 120°C
- Cook & Regen: 30-180°C

Scandinavian safety concept

- Oven door with ventilated heat-reflecting glass
- CTD Cool Touch Door (max. outside temperature of 65°C)
- 2-step door handle in stainless steel for optimum safety
- Integrated drip tray in stainless steel, self-emptying
- Automatic door stop at 110° and 180°
- Runners with stop
- Max. working height of 135 cm incl. stand

K ovens standard features

Panel with turn switch and digital display
 Memory of 10 programmes - each with up to 3 steps
 Cook book with 5 preset programmes
 Combi 1 and Combi 2: 30-250°C
 Semi-automatic cleaning system
 Automatic cooling
 Error registration system



KPE ovens standard features

Panel with soft keys and TFT display
 Memory of 200 programmes - each with up to 10 steps
 Cook book with 65 preset programmes
 ClimaOptima® automatic humidity control: 70-250°C
 Proving: 30-40°C
 CombiWash® fully automatic cleaning system
 Integrated hand shower
 Manual or automatic cooling
 Automatic service diagnosis system
 Multi-point probe, external location
 Delta-T and Cook & Hold
 HACCP quality control
 USB connection



Optional features (visit www.houno.com)

CombiWash® fully automatic cleaning system (K)
 Integrated hand shower (K)
 Multi-point probe, external location (K)
 Extra multi-point probe, external location (KPE)
 Removable cassette rack or rack for plates
 Trolley for rack
 Insulating thermal blanket
 Stacking kit for CombiPlus (1.06)
 Extra door, PassThrough version
 Marine version
 Stands e.g. with runners or shelf
 Various voltages

Visual Cooking 1.10

Combi ovens model K / KPE
Capacity: 10 x 1/1 GN trays

Visual Cooking

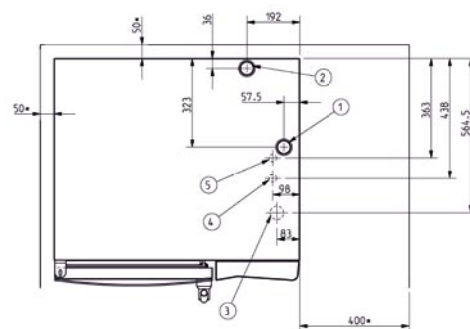
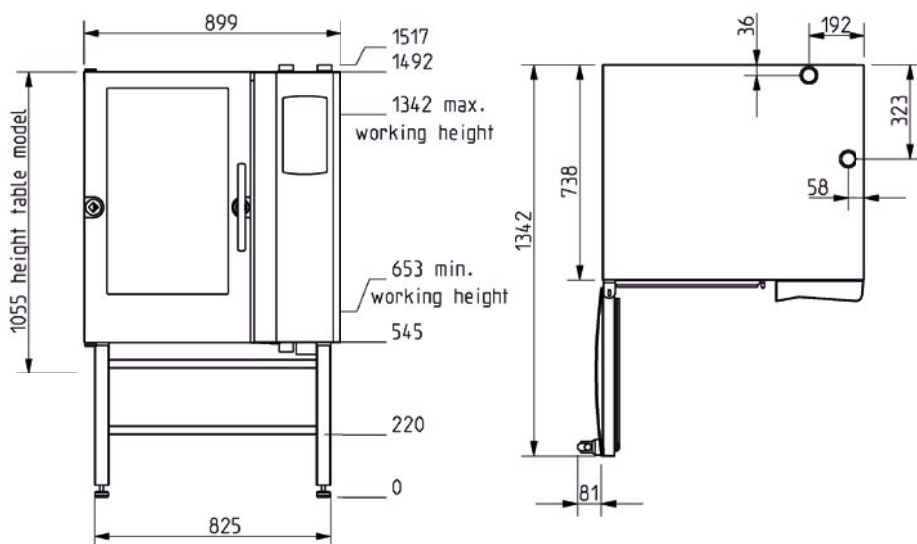

Installation 1/1 GN

- ① Ø 50 mm exhaust tube
- ② Ø 50 mm tube for drain connection
- ③ Lead-in for supply line
- ④ 3/4" water connection for soft water
- ⑤ Option together with ④
3/4" water connection for raw water

Consult HOUNÖ's Service & Installation manual for further information.

CAPACITY	
Tray size	1/1 GN eller 400 x 600
Number of runners, 65 mm	10
Number of runners, 85 mm	8
Portions	150
Potatoes	40/32 kg
Rice	10 kg
Vegetables	25 kg
Roasts	30-35 kg
Chickens, 900 g	24 stk.
Rolls	150 stk.
SPECIFICATIONS	
Voltage	400V AC 3N + E 50/60 Hz
Wattage	18 kW
Current	26 A
Water connection	3/4" outside
Drain	Ø 50 mm outside

DIMENSIONS	OVEN
Width	900 mm
Height - table model	1055 mm
Height with stand	1495 mm
Depth (excl. handle)	831 mm
Weight	175 kg
DIMENSIONS	OVEN PACKED
Width	1200 mm
Height - table model	1255 mm
Height with stand	1700 mm
Depth (excl. handle)	1000 mm
Weight	190 kg