

Visual Cooking 1.06

Combi ovens model K / KPE
 Capacity: 6 x 1/1 GN trays



General features

- Steam technology: steam generator
- Reversible fan ensures perfect roasting and baking
- Adjustable fan speed with 9 steps
- Optional door hinging, left (standard) or right
- Optional distance between runners, 65 mm or 85 mm
- Optional trays size, 1/1 GN (standard) or 400x600 mm
- 2-piece rack, lengthwise insertion
- Easy-to-clean design
- IP X5 protection
- Cabinet and oven chamber in BS 304 S 31 stainless steel
- Rounded corners in oven chamber
- Easily detachable door seal
- Indicator of water shortage in steam generator
- AFS Auto Flush System in steam generator
- Halogen light in oven chamber
- Table model prepared for stand
- Timer function with current time, date and timer
- Manual humidity pulsing
- Preheating up to 300°C

General operating modes

- Hot air: 30-250°C
- Low-temperature steaming: 30-99°C
- Steaming: 100°C
- Forced steaming: 120°C
- Cook & Regen: 30-180°C

Scandinavian safety concept

- Oven door with ventilated heat-reflecting glass
- CTD Cool Touch Door (max. outside temperature of 65°C)
- 2-step door handle in stainless steel for optimum safety
- Integrated drip tray in stainless steel, self-emptying
- Automatic door stop at 110° and 180°
- Runners with stop
- Max. working height of 135 cm incl. stand

K ovens standard features

Panel with turn switch and digital display
 Memory of 10 programmes - each with up to 3 steps
 Cook book with 5 preset programmes
 Combi 1 and Combi 2: 30-250°C
 Semi-automatic cleaning system
 Automatic cooling
 Error registration system



KPE ovens standard features

Panel with soft keys and TFT display
 Memory of 200 programmes - each with up to 10 steps
 Cook book with 65 preset programmes
 ClimaOptima® automatic humidity control: 70-250°C
 Proving: 30-40°C
 CombiWash® fully automatic cleaning system
 Integrated hand shower
 Manual or automatic cooling
 Automatic service diagnosis system
 Multi-point probe, external location
 Delta-T and Cook & Hold
 HACCP quality control
 USB connection



Optional features (visit www.houno.com)

CombiWash® fully automatic cleaning system (K)
 Integrated hand shower (K)
 Multi-point probe, external location (K)
 Extra multi-point probe, external location (KPE)
 Removable cassette rack or rack for plates
 Trolley for rack
 Insulating thermal blanket
 Stacking kit for CombiPlus (1.06, 1.08 & 1.10)
 Extra door, PassThrough version
 Marine version
 Stands e.g. with runners or shelf
 Various voltages

Visual Cooking 1.06

Combi ovens model K / KPE
Capacity: 6 x 1/1 GN trays

Visual Cooking

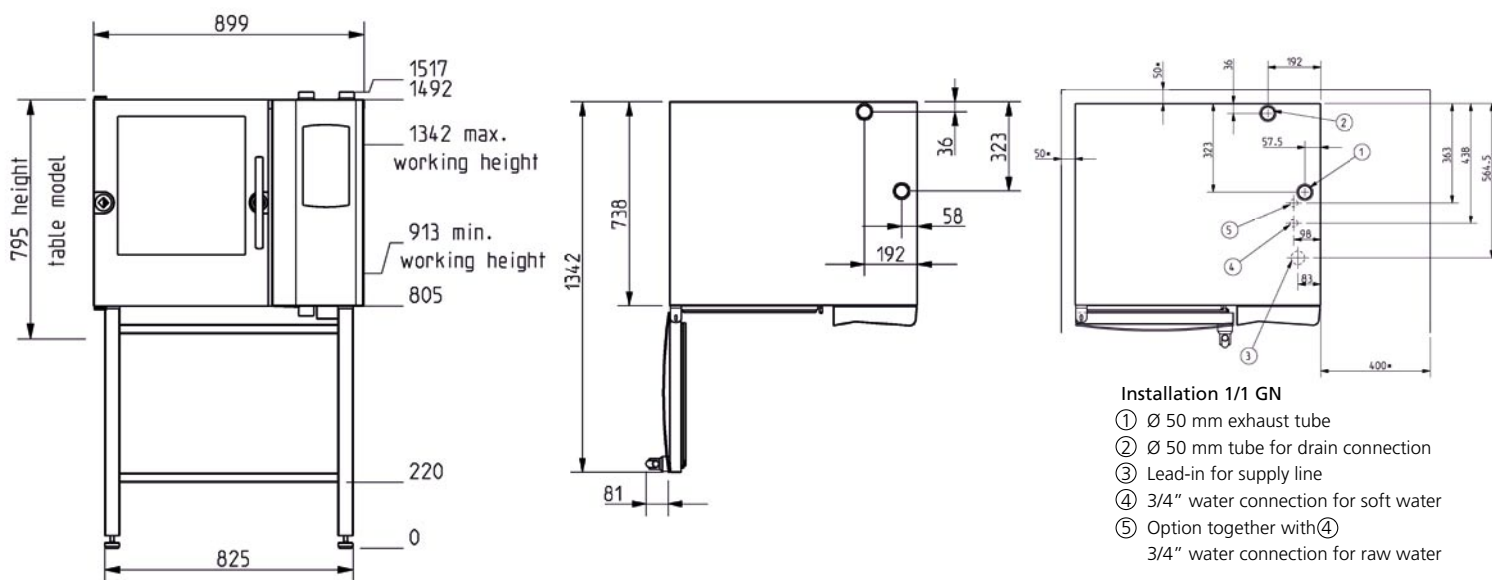

Consult HOUNÖ's Service & Installation manual for further information.

CAPACITY	
Tray size	1/1 GN or 400 x 600
Number of runners, 65 mm	6
Number of runners, 85 mm	5
Portions	90
Potatoes	24/20 kg
Rice	6 kg
Vegetables	15 kg
Roasts	18-21 kg
Chickens, 900 g	16 pcs
Rolls	90 pcs
SPECIFICATIONS	
Voltage	400V AC 3N + E 50/60 Hz
Wattage	9 kW
Current	13 A
Water connection	3/4" outside
Drain	Ø 50 mm outside

DIMENSIONS	OVEN
Width	900 mm
Height - table model	795 mm
Height with stand	1495 mm
Depth (excl. handle)	831 mm
Weight	135 kg
DIMENSIONS	OVEN PACKED
Width	1200 mm
Height - table model	995 mm
Height with stand	1700 mm
Depth (excl. handle)	1000 mm
Weight	150 kg